

« FOR ALL KINDS OF THRESHOLDS, STEPS AND EDGES »

ECO-FRIENDLY RAMPS

WESTECH
HEALTH CARE LTD.

JANUARY 2024

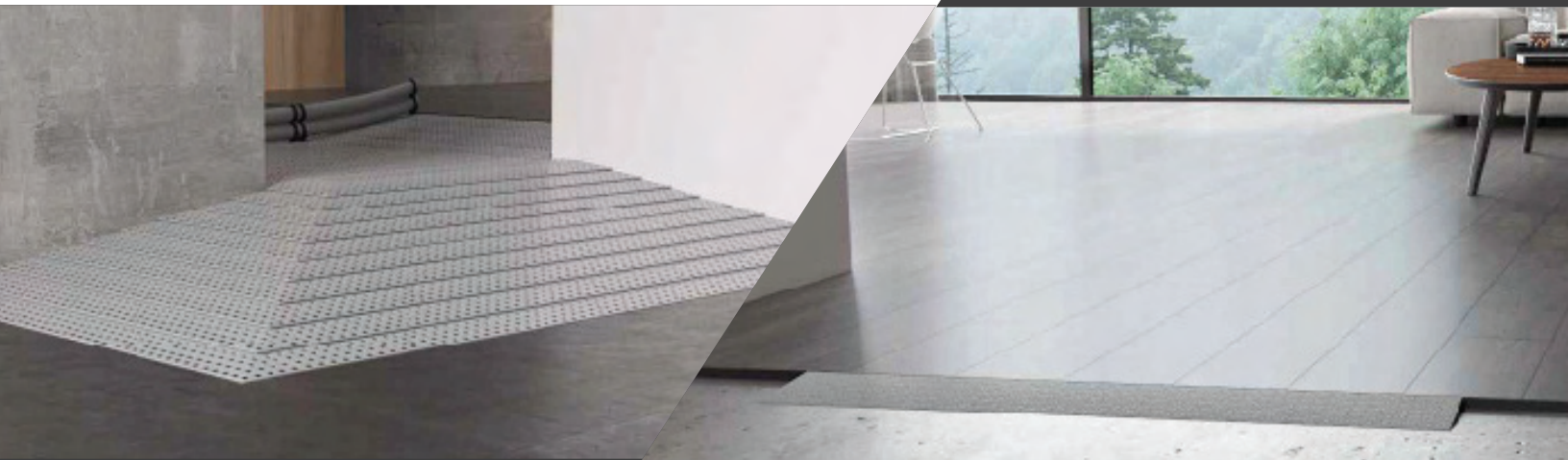

Remove the ramp,
clean the area,
put it back
again and again ...

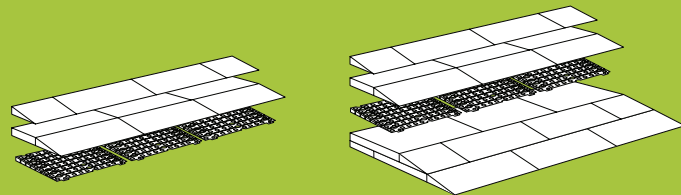

Improve everyday life



QUICK RAMPS



Danish Design

QuickRamps are designed, pat. pend. and produced at our factory in Denmark.

Ramps for tresholds made in one piece, very easy to install and to adjust

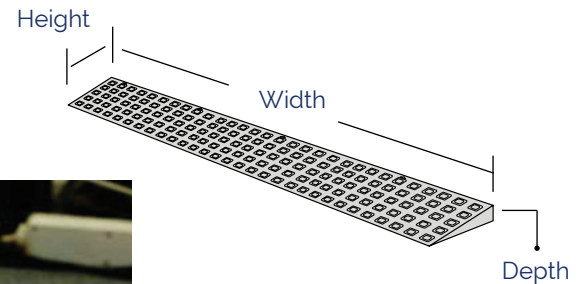

The small arrows indicate Quick lock placement. Read more in our brochure Quickramps.

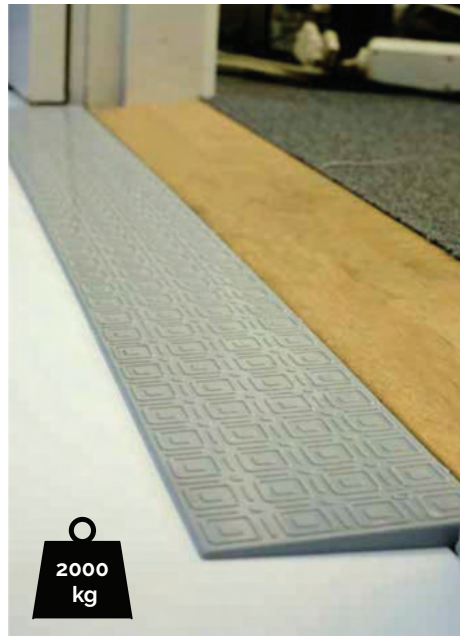

Excellent QuickRamps can bear a weight of 2000 kg.

Product Information

Height

- 4 mm 16 mm
- 6 mm 18 mm
- 8 mm 20 mm
- 10 mm 24 mm
- 12 mm 28 mm

Width

39.3 inches /100 cm standard.
Can be cut down in size below 39.3 inches/100 cm, to fit ordered requirements.

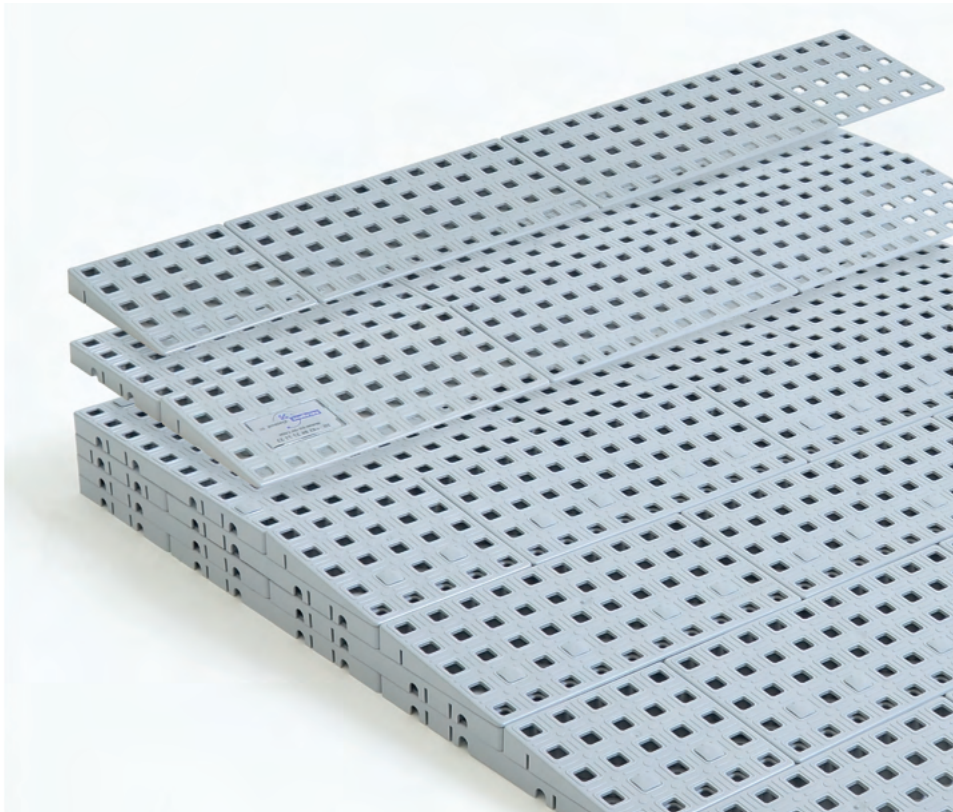

**OTHER
PRODUCT AREAS**

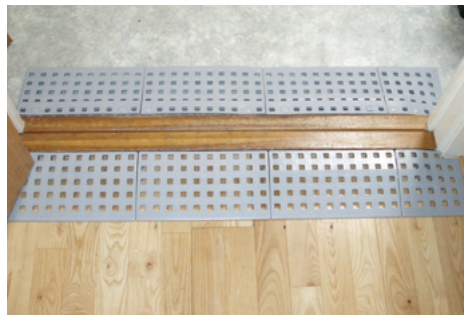

Solutions for bathrooms.
Read more in our brochure
Excellent shower.

Solutions for thresholds.
Read more in our brochure
Threshold ramps.

Solution for balconies
and balcony accesses.
Read more in our
brochure **Raising
Balconies.**



Side-Specific ramps with landings, rails and markings.
Read more in our brochure **Side-Specific ramps.**



BATHROOM SOLUTIONS

A wheelchair or commode chair can cause many problems. Even the lowest brim may make rolling difficult and require heavy lifting from the nursing staff. Excellent ramps and tiles provide better accessibility and can be fitted to any bathroom.

Solutions with Excellent ramps and tiles are fast and economic and do not require any conversion of the bathroom.

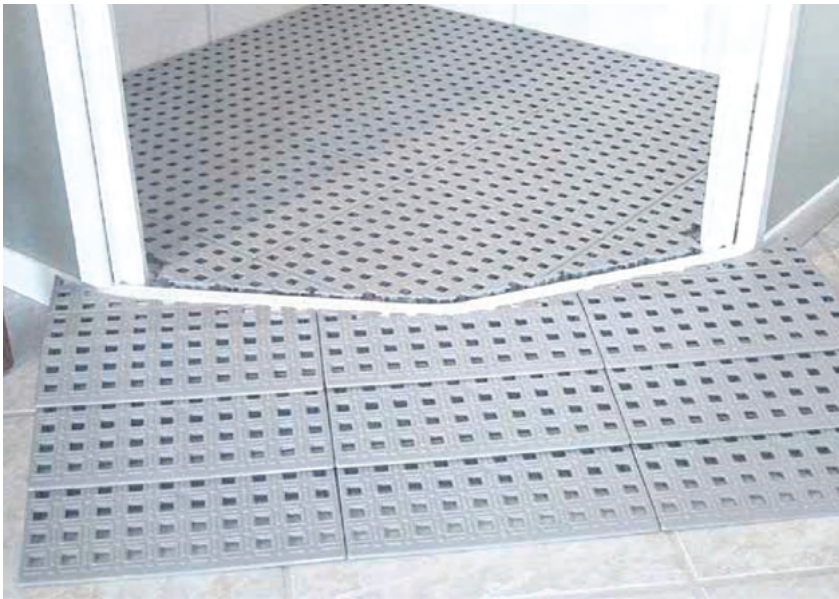

Example of a typical shower unit. A shower tray like this one will be filled up with tiles and if necessary fitted with a small ramp.



Example of a typical shower unit. A shower tray like this one will be filled up with tiles and if necessary fitted with a small ramp.

THRESHOLD SOLUTIONS

Access to the bathroom and the other rooms of a house is a necessity, and for this we offer a range of solutions. We can provide ramps not only in various heights and widths, with and without corner, but also in a number of different colours.



RAMP KIT

Height:

Width:
29.5 inches / 75 cm

Width:
39.3 inches / 100 cm

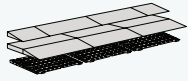

0.7 - 2.16 inches
(1.8 - 5.5 cm)

KIT 001

KIT 101

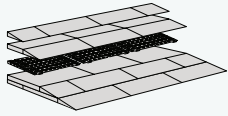

1.4 - 3.6 inches
(3.6 - 9.1 cm)

KIT 002

KIT 102

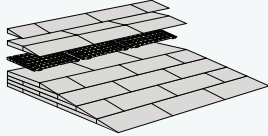

2.8 - 5 inches
(7.2 - 12.7 cm)

KIT 003

KIT 103

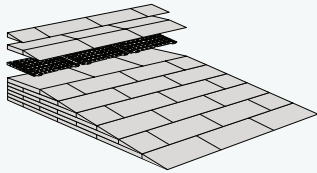

4.3 - 6.4 inches
(10.8 - 16.3 cm)

KIT 004

KIT 104

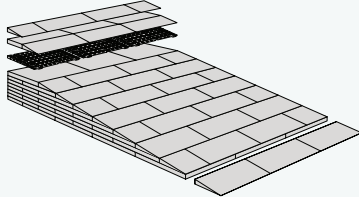

5.7 - 7.8 inches
(14.4 - 19.9 cm)

KIT 005

KIT 105

RAMP KIT CORNER

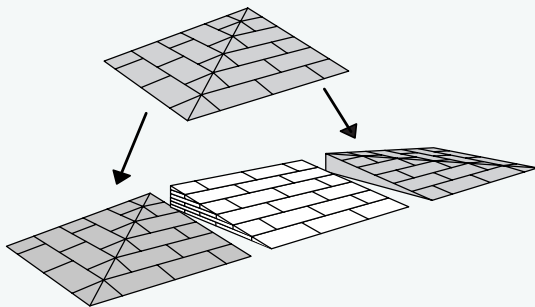

The corners fits both left and right side of the KITS:

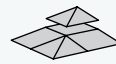

KIT 001 Corner

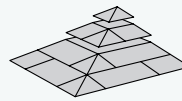

KIT 002 Corner

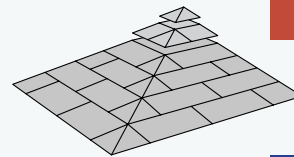

KIT 003 Corner

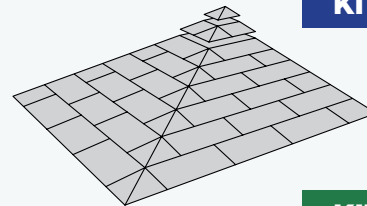

KIT 004 Corner

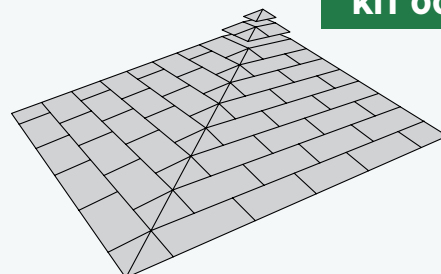

KIT 005 Corner

RAMP KIT PLATFORM

Width:
29.5 inches/75 cm

Width:
39.3 inches / 100 cm

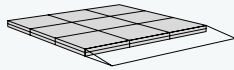

KIT 001 PLATFORM

KIT 101

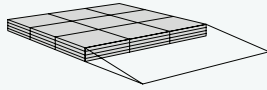

KIT 002 PLATFORM

KIT 102

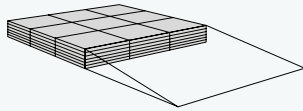

KIT 003 PLATFORM

KIT 103

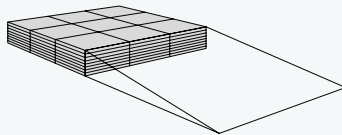

KIT 004 PLATFORM

KIT 104

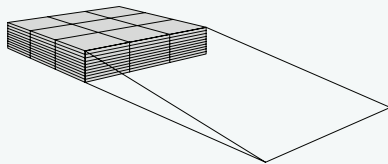

KIT 005 PLATFORM

KIT 105

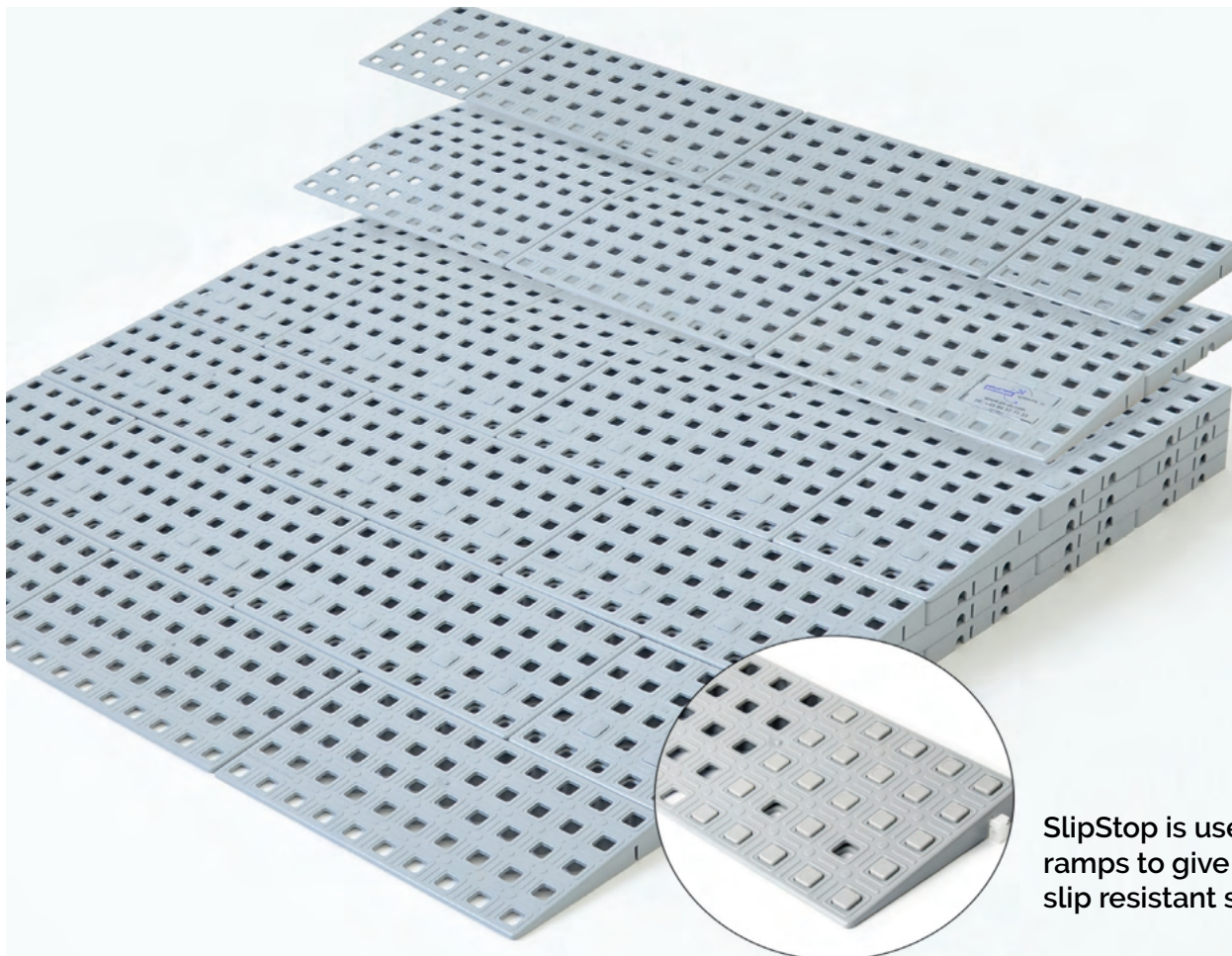

SlipStop is used for outdoor ramps to give an extremely slip resistant surface.

INSPIRATION

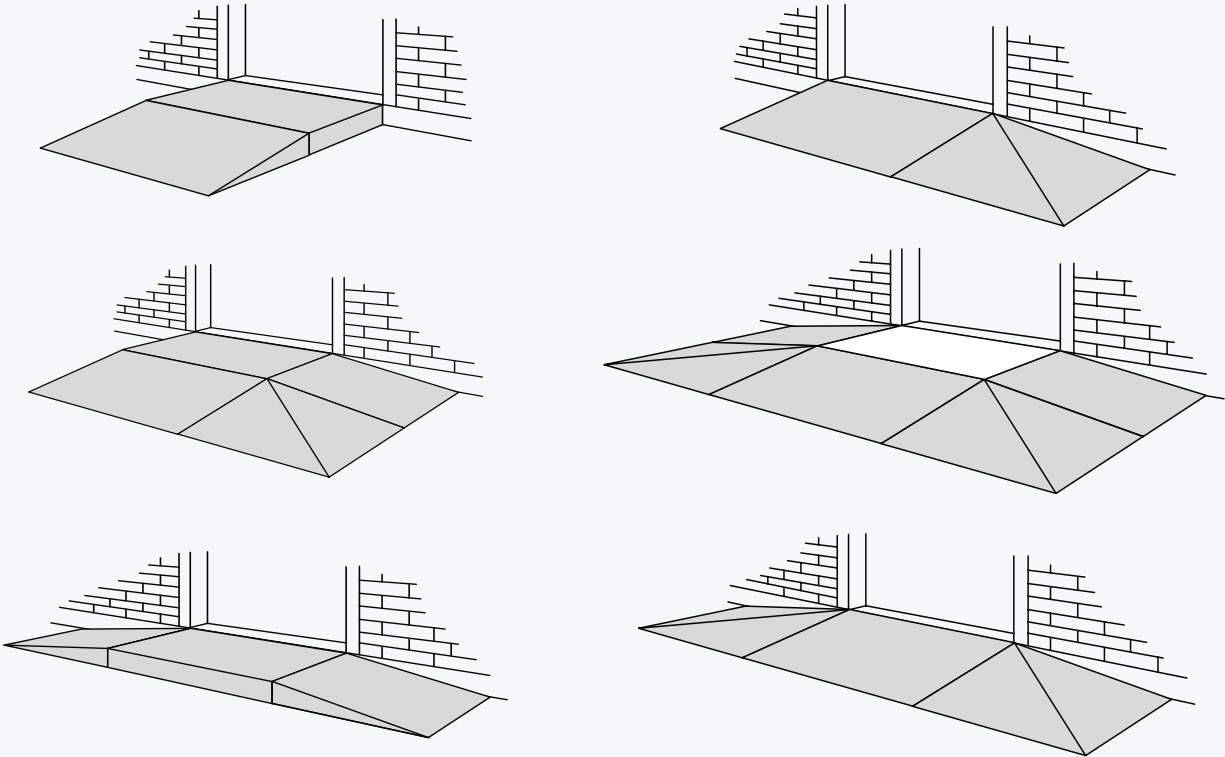

SURFACES

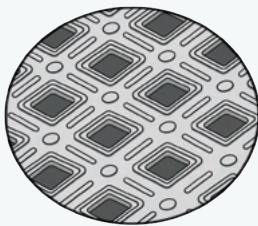

Surface	Use	Products available
With Holes	Indoor	KIT Platform Corner

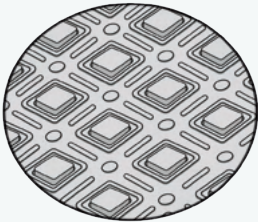

Surface	Use	Products available
SlipStop	Outdoor	KIT Platform Corner



Surface	Use	Products available
NO holes	Indoor	KIT Platform

RAMP ADJUSTER

With the Ramp Adjuster it's possible to make fine adjustments of ramps. Adjustments with only 2 mm differences in height:

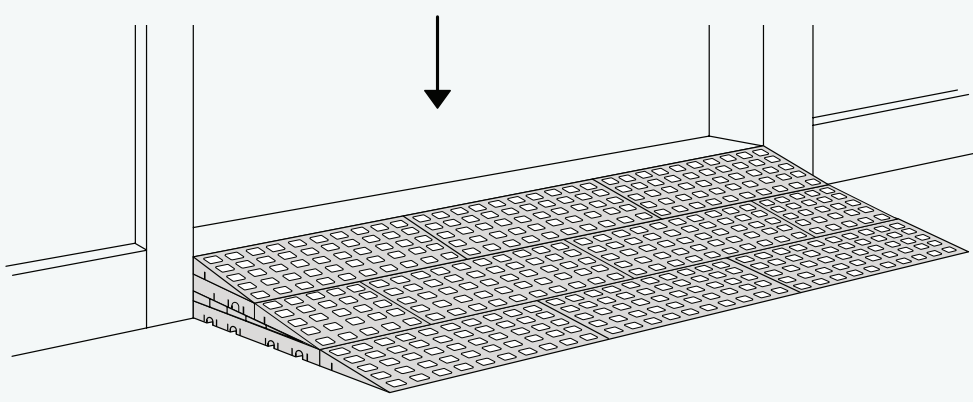
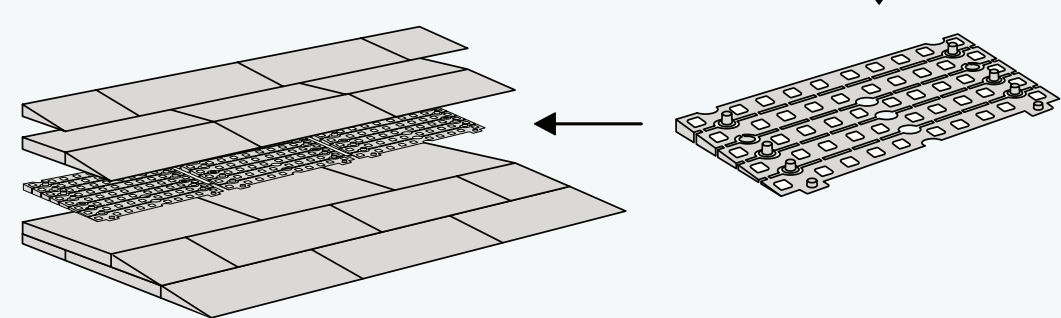
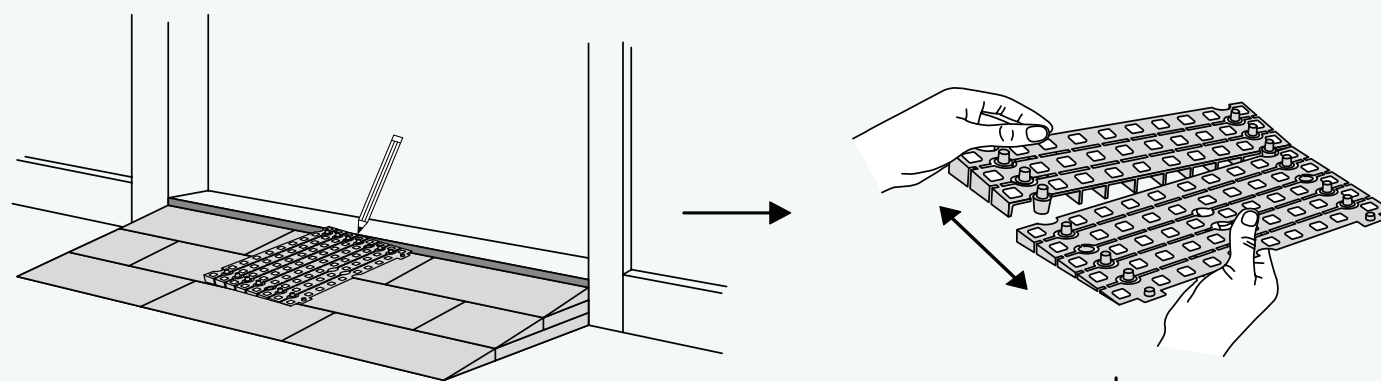
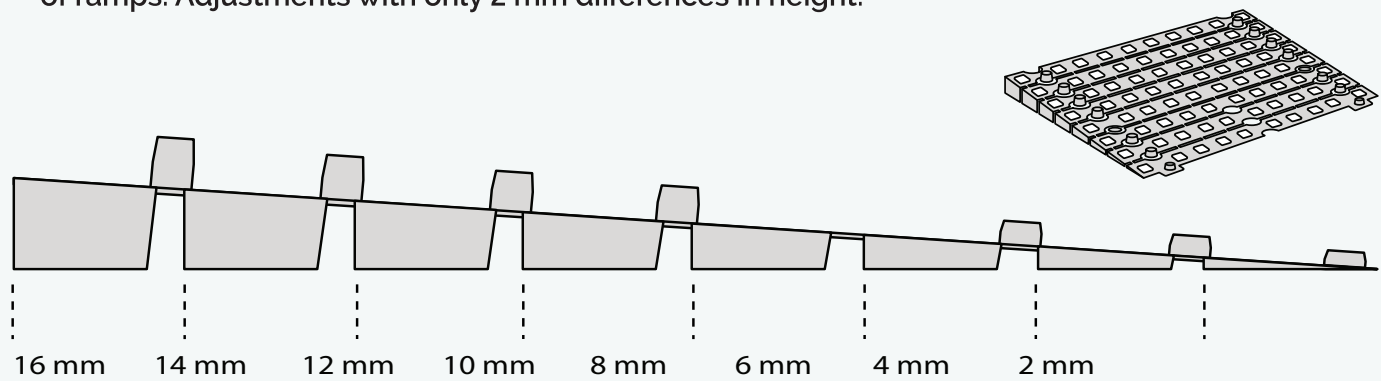

SPAREPART PACKAGES

KIT Sparepart 1



Bag of 1 Ramp Adjuster

KIT Sparepart 2



Bag of 1 Mounting Pad + Screw

KIT Sparepart 3



Bag of 10 R-Lock

KIT Sparepart 4



Bag of 10 T-Lock

KIT Sparepart 5



Bag of 10 S-Lock

KIT Sparepart 6



Bag of 10 C-Lock

KIT Sparepart 7



Bag of 10 Plastprop

KIT Sparepart 8



Bag of 3 Expansion Guide

WESTECH

HEALTH CARE LTD.

Westech Health Care Ltd.
154 - 5255 McCall Way NE, Calgary, Alberta T2E 7J5
2-8400 Parkhill Drive, Milton, Ontario L9T5V7

www.westechhealth.com :: orders@westechhealth.com :: sales@westechhealth.com :: 1-844-323-0022

Visit www.ramp-kits.com for videos and information.



Customer Service

Education
& Technical Support



For more information:
www.westechhealth.com
844-323-0022

Westech Health is on a mission to enhance people's lives by providing access to industry leading healthcare product manufacturers and developers.